

GRIFFIN LARGE RECEPTION EXHIBITION COUNTER

FEATURES:

- Double Exhibition Counter Case
- Black Rotor Moulded MDPE Transport Case
- 2x Large Hard Cases 990mm x 640mm / 11kg
- Includes Printed Graphic & Counter Top
- Ideal For Storing & Transporting Material
- Black Double Counter Top Fits Across Cases
- Includes 6 Internal Shelves
- Portable & Easy To Transport To Events
- Built in Transport Wheels



Includes Printed Graphic & Folding Top



Includes 6 Internal Shelves

DIMENSIONS:

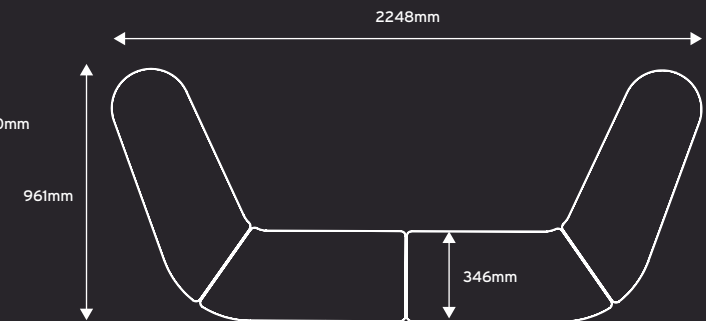
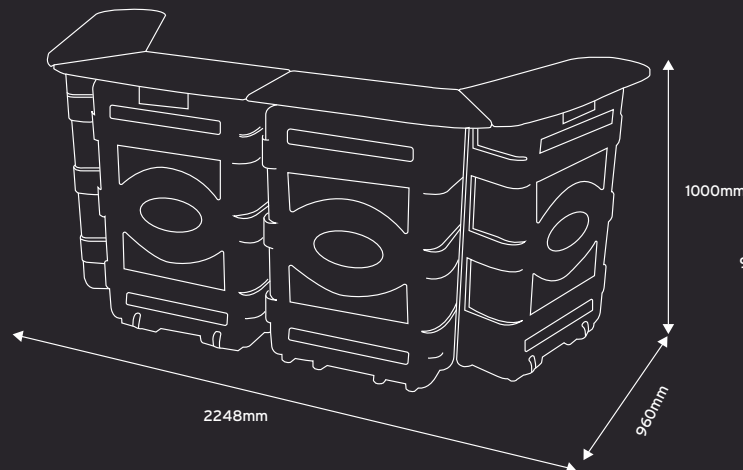

01733 511030
sales@xldisplays.co.uk