

TYPHOON FORECOURT WATER BASED SIGN

Stylish spring mounted snapframe sign with advanced performance features.

FEATURES:

- Available in two colour options with advanced style, stability and performance.
- Front opening aluminium snapframes for quick and easy poster change. Opening tool supplied for easy access.
- High strength Aluminium Composite Material back panel has smooth white surfaces for self adhesive vinyl graphics or liquid chalk pen messaging if posters are not in use.
- Unique water-fillable HDPE base with built-in wheels.
- Heavy duty spring mounts ensure stability by allowing panel deflection in the wind.
- Anti-glare poster cover sheets ensure clarity and vibrancy by protecting posters from UV fade.
- Soft round corners for safety.
- Transit trolley available to aid movement when base is full (30" x 40" and A0 sizes only).
- Ideal for forecourts, entrance approaches, car parks, retail outlets and shopping centres.
- Supplied with 2 piece spanner set.



Nylon feet reduce wear and increase stability on uneven surfaces.



Exclusive design base has optimised water capacity for advanced stability.



Higher specification corner brackets on 30" x 40" and A0 sizes.

DIMENSIONS:

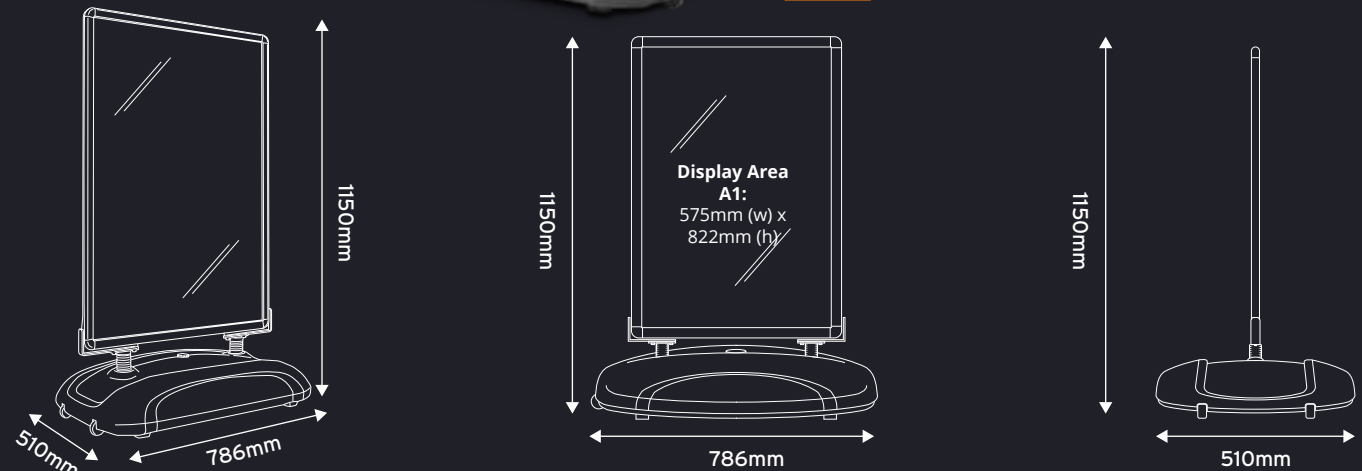

POSTER SIZE	DISPLAY AREA	O/A DIMENSIONS (W X H X D MM)	WEIGHT (KG) EMPTY/FULL
A1	575 X 822	786 X 1150 X 510	12/48
30" X 40"	744 X 997	956 X 1342 X 609	18.3/81
A0	823 X 1173	956 X 1515 X 609	21/83



01733 511030
sales@xldisplays.co.uk

ALL SIZES AVAILABLE IN: SILVER FRAME WITH GREY BASE OR BLACK FRAME WITH BLACK BASE