

# TENSABARRIER OUTDOOR RETRACTABLE BARRIER POST

Weather Resistant

Features a fillable base for a permanent or temporary barrier solution. Ideal for outdoor applications.

## FEATURES & BENEFITS

- The outdoor post features a lightweight plastic post that screw fixes into a hollow plastic base that can be filled with either sand or water to stabilise.
- When empty, the base can be easily moved, or quickly dismantled from the post. The hexagonal base allows for it to be stacked for easy storage and has a carry handle for easier transportation.
- The filling point on the base is easily located to be able to remove quickly and maximise filling volume of either sand or water.
- Weather resistant for outdoor use, but shouldn't be permanently placed outside.
- Safest barrier on the market – our cassettes have a unique braking system for slower webbing retraction.

## APPLICATIONS

- Ideal for garden centres and outdoor retail spaces.
- Use to guide public during events.
- Eliminate unsafe working conditions by clearly defining routes.
- Restrict access to dangerous areas.
- Indoor and outdoor use.



### Base Options



Outdoor Base

### Post Finishes



Four plastic finishes available

### Webbing Options



Standard Webbing  
50mm width

### Webbing Lengths



Two lengths available

### Webbing Designs



Full range of colours, designs  
and custom options

### Tape End Options



Six tape end options available

## DIMENSIONS:

## TENSATOR®

### PRODUCT SPECIFICATION

- Plastic post available in 4 UV stable colours.
- Grey plastic fillable base, which allows for temporary or permanent retractable barrier system.
- Shipped flat packed with no tools required.
- Available with any Tensator® standard (50mm) webbing options.
- Modular webbing cassette – all cassettes come as standard with our four-point anti-tamper webbing connectivity. This allows you to connect other TensabARRIER® products to the receiver splines on the cassette head.
- Compatible with all TensabARRIER® accessories including our range of post top signage.
- Available to buy in a twin pack.

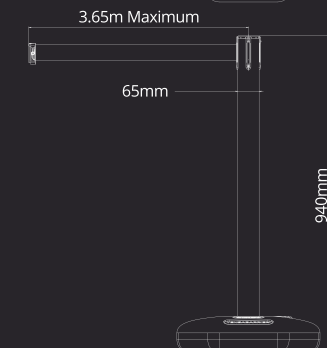

Weight 1.8kg empty  
8kg filled with water



01733 511030  
sales@xl displays.co.uk